

QUOTATION DRAWING

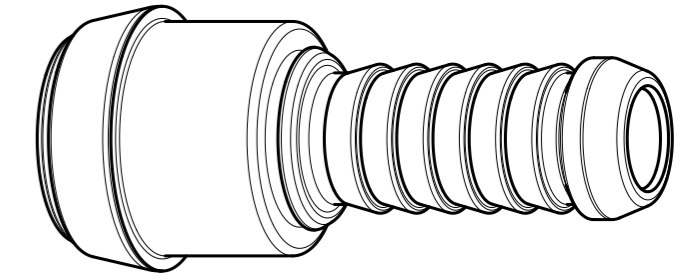

MASSSTAB/SCALE 2:1

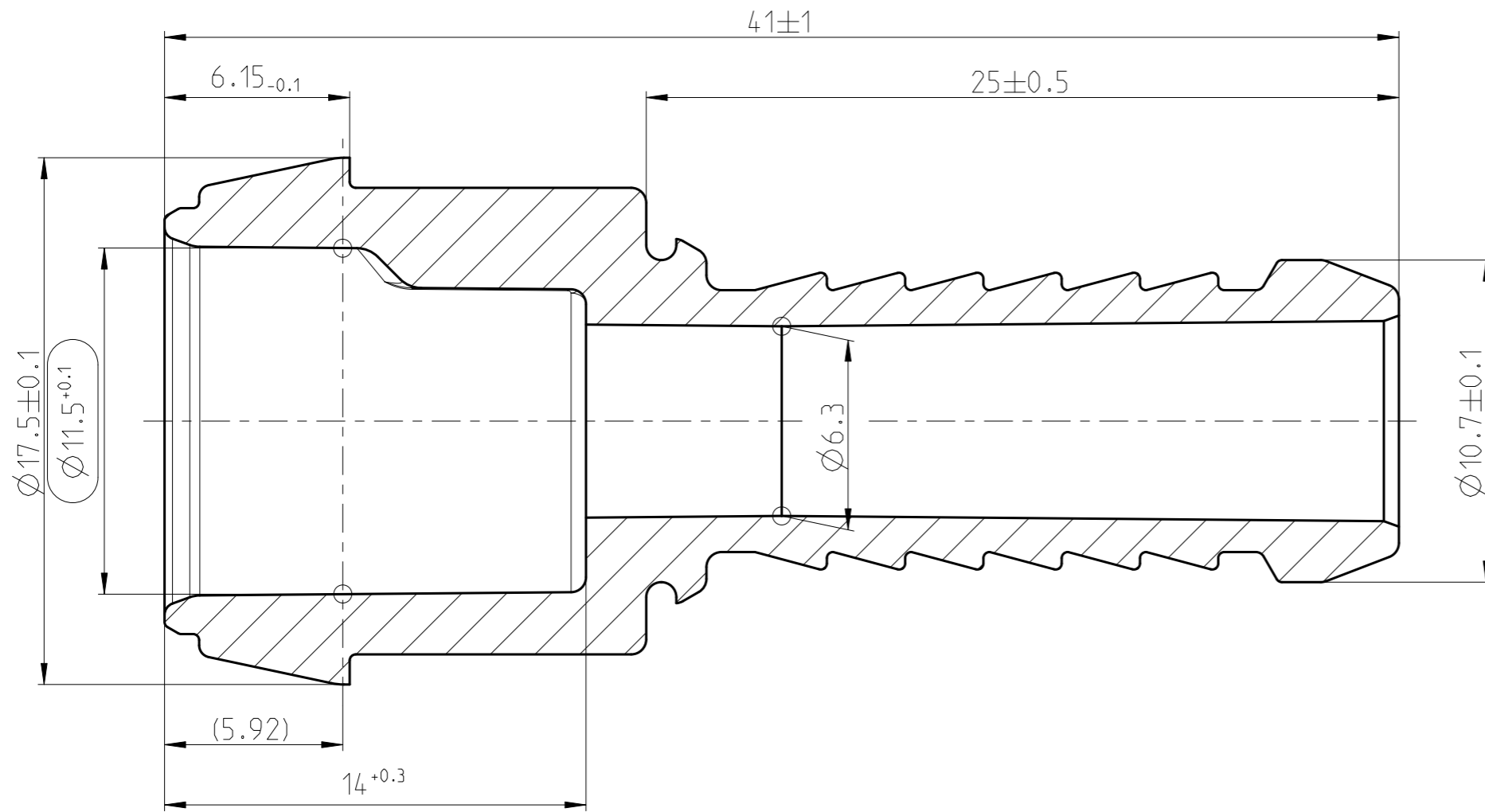
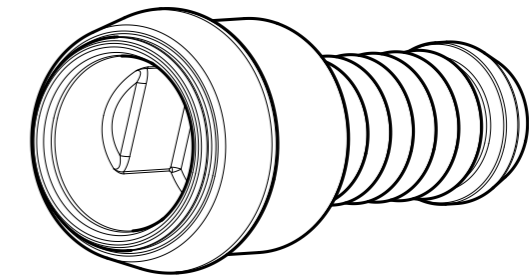

MASSSTAB/SCALE 2:1

NORMAQUICK - ASSEMBLY MARKING	
Customer part-No.:	-
Trademark:	-
Manufacturer code:	NORMA-RSS
NORMA date code:	XX YY
Material code molding part:	>PA66-GF30<

INDEX PART	DWG	QTY	REVISION SUMMARY	CHANGE-NO	DATE	DRAWN	CHECKED
-	E	-	drawing separated	-	2018-11-14	Reichl	Reuter
-	D	-	Ø12.1±0.1 war Ø12±0.1	601788	2003-11-06	Imago-Gr	Strauss
-	C	-	2036 0200 125 war 2036 0100 038	601335	2002-09-25	Imago-Gr	Strauss
-	B	-	war Ø8.7-0.1	600511	2001-02-19	Bauer	Bahner
-	A	-	Beschriftung hinzu , poliert hinzu	600414	2000-11-22	Imago-Gr	Bahner

1st ANGLE PROJECTION	ACCORDING TO:	-	PART NAME:	V3 NW 6-8-0° Double spigot			
	SCALE:	5:1	DATE: YYYY-MM-DD	2000-06-16	NAME	Imago-Gr	
	MM		DRAWN		CHECKED	Bahner	
PROJECT-NO.:	NORMA Germany GmbH Postfach 1149 63461 Maintal			CUSTOMER:	-		
999 000 5614				CUSTOMER-NO.:	-		
CAD-SYSTEM:	(C) COPYRIGHT NORMA GROUP DIN ISO 16016			NORMA-NO.:	0717 8005 006	INDEX PART	DWG
Creo 3.0 M140						E	Q
DRAWING-NAME.:	07178005006_Q						FORMAT
							A3
							SHEET
							1/1